

Reetray 25

Semiautomatic Sealing Machine



Table top



h MAX 270 mm



25TC



25 PAIL



Reepack

Packaging Machinery Supplies

Dati Tecnici	Technical Data	Technische Daten	Reetray 25 - 25TC
Dimensioni totali	Overall dimensions	Abmessungen der Maschine	675 x 880 x h725 mm 675 x 880 x h1520 mm (25TC)
Peso totale incl.pompa vuoto	Weight incl.pump	Gewicht mit Pumpe	130 Kg - 190 Kg (25TC)
Max dimensione vaschetta	Max tray dimensions	Max Abmessungen der Schale	430 x 315 mm
Max profondità vaschetta	Max tray depth	Maximale Tiefe der Schale	95 mm (150)
Max larghezza film sigillatura	Max width of top web	Maximale Oberfolienbreite	470 mm
Max diametro bobina film	Max diameter of web roll	Maximale Durchmesser Folienrolle	300 mm
Diametro mandrino bobina	Diameter of web roll mandrel	Durch. des Folienaufnahmedorns	70 - 76 mm
Pompa vuoto	Vacuum pump	Vakuumpumpe	20 m ³ /h - (40-60 m ³ /h 25TC)
Alimentazione elettrica	Electrical supply	Elektrischer Anschluss	1/N/PE AC 230V - 50Hz* 3/N/PE AC 400V - 50Hz (25TC)*
Assorbimento	Power consumption	Mittlere Leistung	max 8,8 KW
Aria compressa	Compressed air	Pressluft	6 bar - 7Nl/c
Numero cicli macchina	Machine capacity	Leistung der Maschine	2 - 6 cycles / min. max 3 con compressore/with compressor

* Differenti tipologie di alimentazione elettrica a richiesta. / Different kinds of electrical supply by request. / Verschiedene Ausstattungen der elektrischen Speisung nach Anfrage.

Lay-out Reetray 25

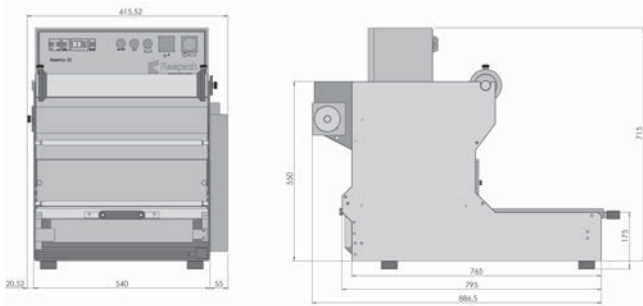

Lay-out Reetray 25TC

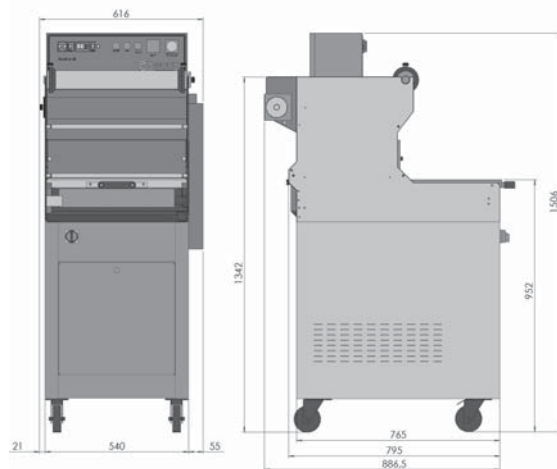

Optionals:

- Profondità camera vuoto 150 mm / Down vacuum chamber 150 mm height
Tiefe vom Vakuumkammer 150 mm
- Carrello portante solo con pompa da 20 m³/h
Open-frame trolley with wheels (20 m³/h vacuum pump version only)
Wagen mit Raeder mit 20 m³/h Pumpe
- Espulsore vaschette (solo con camera vuoto profondità standard)
Tray lifting device (standard down vacuum chamber height only)
Schalenauswerfer (nur mit Vakuumkammer mit standard Tiefe)
- Filtro per liquidi / Liquid filter / Filter fuer Fluessige
- Filtro polveri / Air filter / Luftfilter
- Compressore silenzioso / Silenced air compressor
Ruhiger Kompressor

Ulteriori optional a richiesta / Other optional available on request
Zusätzliche Zubehorteile nach Anfrage

Numero e maxime misure vaschette per ciclo. / Number and max. tray dimensions processed per cycle. / Anzahl und max. Schalenabmessungen/Zyklus.

Fronte operatore - Operator side - Bedienersseite

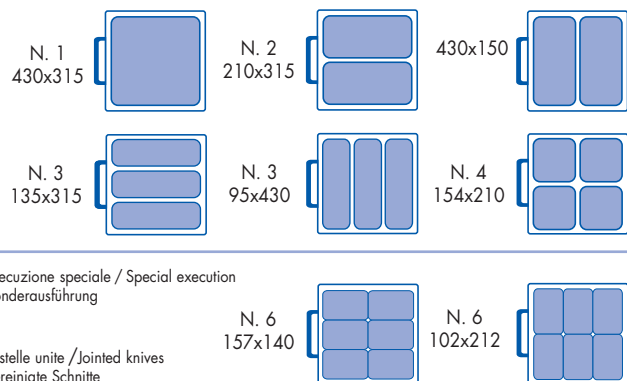

Si riserva la facoltà di apportare modifiche ai dati esposti senza alcun preavviso. / In keeping with improvements, designs and specification subject to change without notice.
Technische Daten und Änderungen ohne Meldung vorbehalten.